

USB HD Video Conference Camera

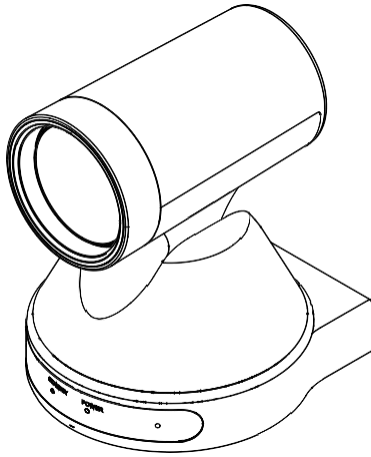

User Manual English (V1.0)

Copyright Notice

All contents of this manual, whose copyright belongs to our corporation cannot be cloned, copied or translated without the permission of the company. Product specifications and information which were referred to in this document are for reference only. We may change, delete, or update any content at any time and without prior notice.



Warning

This is class A production. Electromagnetic radiation at specific frequencies may affect the image quality of TV in home environment.

Catalogue

- 1 Note.....1
- 2 Packing List..... 1
- 3 Quick Start..... 1
- 4 About Product.....2
 - 4.1 Features.....2
 - 4.2 Product Specification.....2
 - 4.3 Interfaces and Buttons..... 3
 - 4.4 Dimension.....4
 - 4.5 Remote Control.....5
 - 4.6 RS-232 Interface.....6
 - 4.7 VISCA Network.....7
 - 4.8 Serial Communication Control.....7
- 5 GUI Settings..... 7
 - 5.1 MENU.....7
 - 5.2 EXPOSURE.....7
 - 5.3 COLOR.....8
 - 5.4 IMAGE.....8
 - 5.5 P/T/Z.....8
 - 5.6 NOISE REDUCTION.....9
 - 5.7 AUDIO.....9
 - 5.8 SETUP.....9
 - 5.9 COMMUNICATION SETUP.....10
 - 5.10 INFORMATION.....10
 - 5.11 RESTORE DEFAULT.....10
- 6 Maintenance and Troubleshooting..... 11

1 Note

• Electric Safety

Installation and operation must accord with electric safety standard.

• Caution to Transport

Avoid stress, vibration or soaking in transport, storage and installation.

• Polarity of Power Supply

The power supply of this product DC 12V, polarity of the power supply plug drawing shows as below.

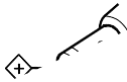

• Installation Precautions

Do not grasp the camera lens when carrying it. Do not touch camera lens by hand. Mechanical damage may be caused by doing so.

Do not use in corrosive liquid, gas or solid environment to avoid any cover (plastic

material) damage. Make sure there is no obstacle within rotation range.

Do not power on before installation is completed.

• Do not Dismantle the Camera

We are not responsible for any unauthorized modification or dismantling.



Specific frequencies of electromagnetic field may affect the image of the camera!

2 Packing List

When unpacking the package, check that all the supplied accessories are included:

Name	Quantity
Camera	1
AC Power Adaptor	1
Power Cable	1
USB Cable	1
Remote Control	1
User Manual	1

3 Quick Start

1) Please check connections are correct before starting.

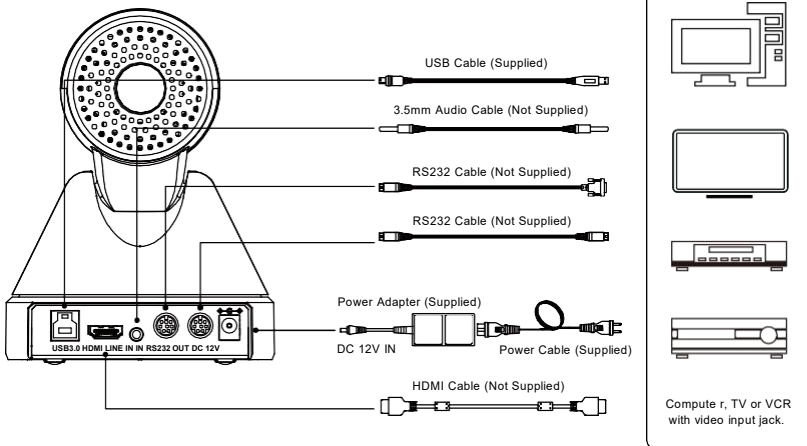

- 2) Connect the power adapter to the power connector on the rear panel of the camera. The power indicator on the front panel of the camera turns on.
- 3) After the camera is powered on, it starts to initialize, upper right turns to the limit position, and then the horizontal and vertical turn to the middle position. When the motor stops running, it means that the initialization is completed. (Note: If preset 0 is saved, the PTZ will turn to preset 0).

4 About Product

4.1 Features

- **USB 3.0**

Full function USB interface, compatible with USB 3.0 and USB 2.0, support audio and encoding output, support the UVC V1.1 protocol and support almost all video conferencing software on the market.

- **1080P Full HD**

Apply Panasonic's 1/2.8 inch, 2.07 million effective pixels high quality HD CMOS sensor, it can reach maximum 1920 x 1080 high resolution and achieve quality image.

- **Built-in Microphone**

Built-in microphone with pickup distance up to 6m, high sensitivity and low noise.

- **72.5° Wide-angle Lens + 16x Digital Zoom**

Use 72.5° wide-angle high-quality lens, support 12x optical zoom and 16x digital zoom.

- **H.264 Slice/H.264 SVC**

The output H.264 stream supports Slice and SVC encoding modes, and suitable for the high-end USB conference video applications.

- **Rich Complete Interface**

Support HDMI and USB3.0, can output the 1080P video simultaneously.

- **Low Illumination**

The new CMOS image sensor with ultra-high SNR can effectively reduce the image noise under low illumination. The application of 2D and 3D noise reduction algorithm greatly reduces the image noise even under the condition of ultra-low illumination, it keeps the picture clean and clear, and the SNR of image is as high as 55dB.

- **Remote Control**

Through the RS232 and USB ports, the camera can be remote controlled by the high-speed communications.

4.2 Product Specification

Name	USB HD Video Conference Camera
Camera	
Video System	1080P60, 1080P50, 1080P30, 1080P25, 720P60, 720P50
Sensor	1/2.8", CMOS, Effective Pixel: 2.07M
Scanning Mode	Progressive
Lens	12x, f=3.5mm ~ 42.3mm, F1.8 ~ F2.8
Digital Zoom	16x
Minimum Illumination	0.5 Lux @ (F1.8, AGC ON)
Shutter	1/30s ~ 1/10000s
White Balance	Auto, Indoor, Outdoor, One Push, Manual, VAR
Backlight Compensation	Support
Digital Noise Reduction	2D&3D Digital Noise Reduction
Signal Noise Ratio	≥55dB
Horizontal Angle of View	72.5° ~ 6.9°
Vertical Angle of View	44.8° ~ 3.9°
Horizontal Rotation Range	±170°
Vertical Rotation Range	±30°

Pan Speed Range	1.61° ~ 75.56°/s
Tilt Speed Range	0.44° ~ 15°/s
H & V Flip	Support
Image Freeze	Support
Number of Preset	255
Preset Accuracy	0.1°
Built-in Microphone	Support
Pickup Distance of Microphone	6m

USB Feature

Operating System	Windows 7/8/10, Mac OS X, Linux, Android
Color System/Compression	YUY2/H.264/MJPEG
Video Format	YUY2 (ISOC): max to 1080P@60fps
	H.264 AVC: max to 1080P@60fps
	MJPEG: max to 1080P@60fps
USB Audio	Support
USB Video Communication Protocol	UVC 1.1
UVC PTZ	Support

Input/Output Interface

USB Interface	1 x USB 3.0: Type B Female
HDMI Interface	1 x HDMI 1.4b
Audio Interface	1 x LINE IN: 3.5mm Audio Interface
Communication Interface	1 x RS232 IN: 8pin Min DIN, Max Distance: 30m, Protocol: VISCA/Pelco-D /Pelco-P
	1 x RS232 OUT: 8pin Min DIN, Max Distance: 30m, Protocol: VISCA network use only
Power Jack	JEITA type (DC IN 12V)

General Specification

Input Voltage	DC 12V
Input Current	1.5A (max.)
Operating Temperature	-10°C ~ 40°C
Storage Temperature	-40°C ~ 60°C
Power Consumption	12W (max.)
MTBF	>30000h
Dimension	99mm x128mm x154mm
Net Weight	0.9Kg

4.3 Interfaces and Buttons

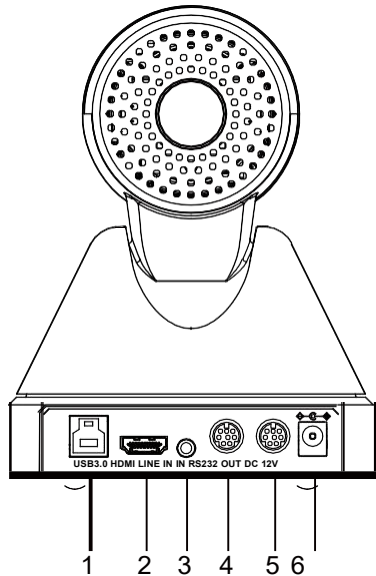

Item	Name
1	USB 3.0 Interface
2	HDMI Interface
3	LINE IN Interface
4	RS232 IN Interface
5	RS232 OUT Interface
6	DC 12V Power Interface

4.4 Dimension

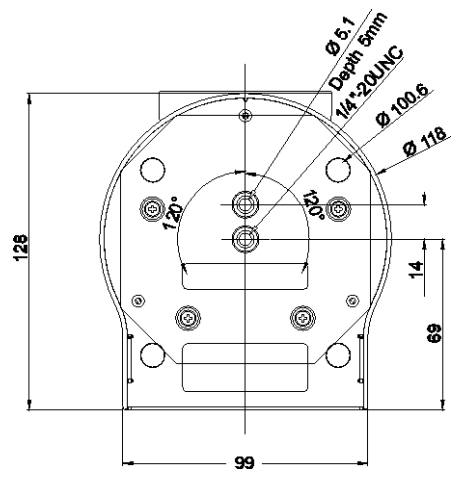
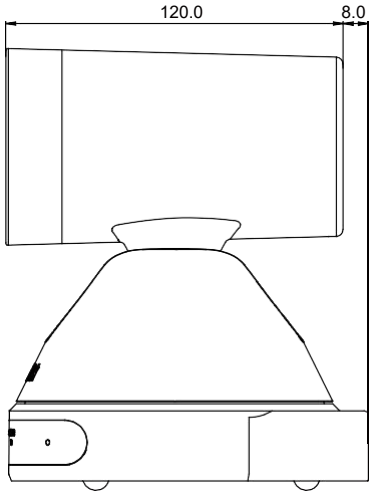
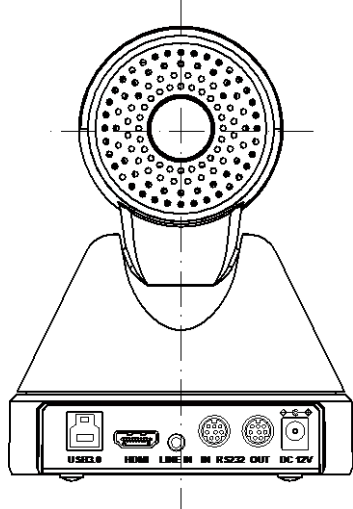
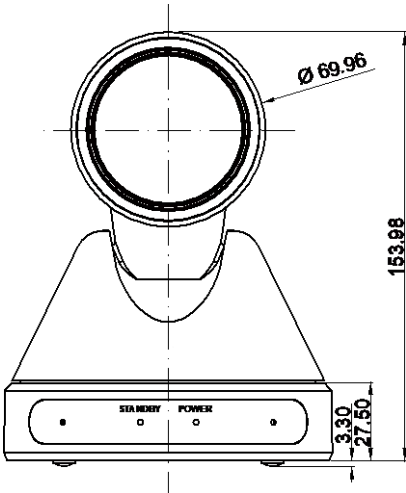

4.5 Remote Control

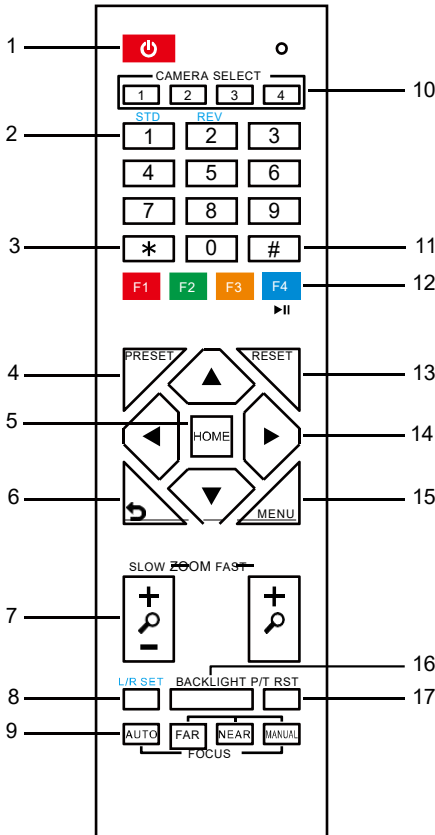

Key Description

1. **⏻ (Standby) Key**

Press to enter standby mode. Press again to resume to normal mode.

Note: The power consumption in standby mode is approximately half of that in normal mode.

2. **Number Key**

To set preset or call preset.

3. *** Key**

Use with other keys.

4. **Preset Key**

Set preset: Store a preset position.
[PRESET] + Number key (0-9): Set a corresponding preset position.

5. **HOME Key**

Confirm selection or press to turn PTZ back to the middle position.

6. **⬅️ (Return) Key**

Press to return to the previous menu.

7. **ZOOM Key**

- SLOW: Zoom In [+] or Zoom Out [-] slowly.
- FAST: Zoom In [+] or Zoom Out [-] fast.

8. **L/R SET Key**

Press with 1 or 2 key to set the direction of the Pan-Tilt.

- Simultaneously press L/R SET + 1 [STD]: Set the Pan-Tilt turn the same direction as the PTZ control key.
- Simultaneously press L/R SET + 2 [REV]: Set the Pan-Tilt turn the opposite direction as the PTZ control key.

9. **Focus Key**

Focus adjustment:

Press [AUTO] to adjust the focus automatically.

Press [MANUAL] to adjust the focus manually.

When in manual focus mode, press [FAR] to focus on far object or [NEAR] to focus on near object.

10. **CAMERA SELECT Key**

Camera selection:

Press to select and control the camera.

11. **# Key**

Use with other keys.

12. **IR Remote Control Key**

[*] + [#] + [F1]: Address 1

[*] + [#] + [F2]: Address 2

[*] + [#] + [F3]: Address 3

[*] + [#] + [F4]: Address 4

13. RESET Key

Clear the preset position:
 [RESET] + Number key (0-9).
 Or: [*] + [#] + [CLEAR PRESET]: Erase all the preset individually.

14. PTZ Control Key

Press arrow button to perform panning and tilting. Press [HOME] button to face the camera back to front.

15. MENU Key

Enter or exit OSD MENU.

16. BACKLIGHT Key

Backlight ON/OFF: Press repeatedly to enable or disable the backlight compensation.

NOTE:

- Effective only in auto exposure mode.
- If there is a light behind the subject, the subject will become dark, press the backlight key to enable the backlight compensation. Press again to disable this function.

17. P/T RST (PTZ Reset) Key

Press to preset Pan/Tilt self-test.

Image Freezing Function

Manual freeze: Press the [F4] key to open the freezing function, "Freeze" will be displayed on the left upper corner. To cancel the freeze function, press [F4] key again, "Unfreeze" shows on the left upper corner and it will be disappeared automatically five seconds later.

Shortcut Set

- [*] + [#] + [1]: OSD menu default English
- [*] + [#] + [3]: OSD menu default Chinese
- [*] + [#] + [6]: Quickly recover the default
- [*] + [#] + [8]: View the camera version
- [*] + [#] + [9]: Quickly set up inversion

4.6 RS-232 Interface

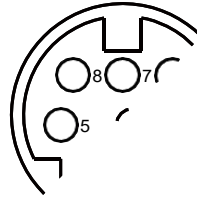

No.	Function
1	DTR
2	DSR
3	TXD
4	GND
5	RXD
6	GND
7	IR OUT
8	NC

The correspondence between the camera and Windows DB-9 pin:

Camera	Windows DB-9
1.DTR	1. CD
2.DSR	2. RXD
3.TXD	3. TXD
4.GND	4. DTR
5.RXD	5. GND
6.GND	6. DSR
7.IR OUT	7. RTS
8.NC	8. CTS
	9. RI

The correspondence between the camera and the Mini DIN pin:

Camera	Mini DIN
1.DTR	1.DTR
2.DSR	2.DSR
3.TXD	3.TXD
4.GND	4.GND
5.RXD	5.RXD
6.GND	6.GND
7.IR OUT	7.NC
8.NC	8.NC

4.7 VISCA Network

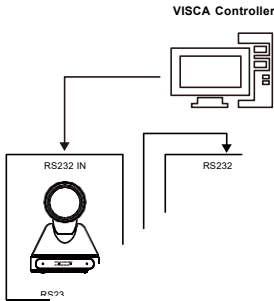

4.8 Serial Communication Control

• **RS232 Communication Control**

The camera is controlled via RS232. The RS232 serial port parameters are as follows:

Baud rate: 2400/4800/9600/38400;

Starting Position: 1 bit

Data bit: 8 bits

Stop bit: 1 bit

Check digit: None

• **List of protocols (omitted)**

The serial port of the camera follows the VISCA/Pelco-D/Pelco-P standard protocol. If secondary development is required, the camera can be controlled according to the standard protocol.

For a detailed list of VISCA/Pelco-D/Pelco-P protocols, contact the manufacturer.

5 GUI Settings

5.1 MENU

Press [MENU] key to display the main menu on the screen. Use the arrow key to move the cursor to desired item and press the [HOME] key to confirm to enter the corresponding sub-menu.

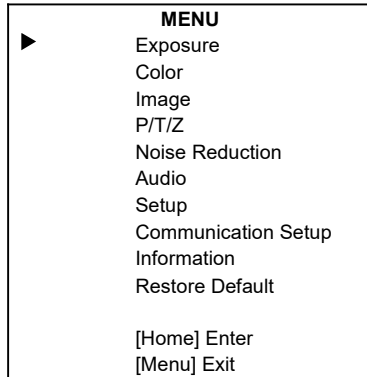

5.2 EXPOSURE

When in main menu page, move the cursor to [Exposure] and press [HOME] key to confirm to enter the exposure page as shown in below figure.

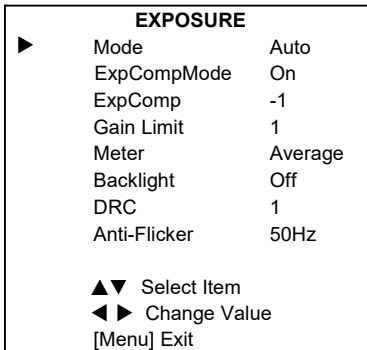

Mode: Auto, Manual, SAE, AAE, Bright.

ExpCompMode (Exposure Compensation Mode): On, Off (Effective only in Automode).

ExpComp (Exposure Compensation Value): -7 ~ 7 (Effective only in ExpCompMode On).

Bright: 0 ~ 17 (Effective only in Bright mode).

Gain Limit: 0 ~ 15 (Effective in Auto, SAE AAE, Bright mode).

Meter: Average, Center, Bottom, Top. (Effective in Auto, SAE, AAE, Bright mode).

Iris: F1.8, F2.0, F2.4, F2.8, F3.4, F4.0, F4.8, F5.6, F6.8, F8.0, F9.6, F11.0, Close (Effective in Manual, AAE mode).

Backlight: On, Off (Effective only in Auto mode).

Shutter: 1/30, 1/60, 1/90, 1/100, 1/125, 1/200, 1/250, 1/350, 1/500, 1/725, 1/1000, 1/1500, 1/2000, 1/3000, 1/4000, 1/6000, 1/10000 (Effective in Manual, SAE mode).

Gain: 0 ~ 7 (Effective only in Manual mode).

DRC: 0 ~ 8.

Anti-Flicker: Off, 50Hz, 60Hz (Effective in Auto, AAE, Bright mode).

5.3 COLOR

When in main menu page, move the cursor to [Color] and press [HOME] key to confirm to enter the color page as shown in below figure.

COLOR		
▶	WB Mode	Auto
	AWB Sens	Low
	RG Tuning	1
	BG Tuning	0
	Saturation	100%
	Hue	7
▲▼ Select Item		
◀▶ Change Value		
[Menu] Exit		

WB-Mode (White Balance Mode): Auto, Indoor, Outdoor, One Push, Manual, VAR.

AWB Sens (The White Balance Sensitivity): Low, Middle, High (Effective in Auto, OnePush mode).

RG Tuning (Red Gain Tuning): -10 ~ 10 (Effective in Auto, OnePush, VAR mode).

BG Tuning (Blue Gain Tuning): -10 ~ 10 (Effective in Auto, OnePush, VAR mode).

R Gain (Red Gain): 0 ~ 255 (Effective only in Manual mode).

B Gain (Blue Gain): 0 ~ 255 (Effective only in Manual mode).

Colortemp: 2500K ~ 8000K (Effective only in VAR mode).

Saturation: 60% ~ 200%.

Hue: 0 ~ 14.

5.4 IMAGE

When in main menu page, move the cursor to [Image] and press [HOME] key to confirm to enter the image page as shown in below figure.

IMAGE		
▶	Luminance	7
	Contrast	7
	Sharpness	4
	B&W Mode	Off
	Flip-H	Off
	Flip-V	Off
	Gamma	0.5
	Image Style	Default
▲▼ Select Item		
◀▶ Change Value		
[Menu] Exit		

Luminance: 0 ~ 14.

Contrast: 0 ~ 14.

Sharpness: 0 ~ 15, Auto.

Flip-H: On, Off.

Flip-V: On, Off.

B&W Mode: On, Off.

Gamma: Default, 0.45, 0.5, 0.56, 0.63, EXT.

Image Style: Default, Norm.

5.5 P/T/Z

When in main menu page, move the cursor to [P/T/Z] and press [HOME] key to confirm to enter the P/T/Z page as shown in below figure.

P/T/Z		
▶	D-Zoom Limit	Off
	AF-Sense	High
	AF-Zone	Front
	Speed By Zoom	On
	Display Info	On
	Call Preset Speed	18
	Pre Zoom Speed	5
▲▼ Select Item		
◀▶ Change Value		
[Menu] Exit		

D-Zoom Limit (Digital Zoom Limit): Off, x2, x4, x8, x16.

AF-Sense (Auto Focus Sensitivity): High, Normal, Low.

AF-Zone (Auto Focus Area): Front, Top, Middle, Bottom.

SpeedByZoom (The Depth of Field Ratio): On, Off.

Display Info: On, Off.

Call Preset Speed: 0 ~ 24.

Pre Zoom Speed: 0 ~ 7.

5.6 NOISE REDUCTION

When in main menu page, move the cursor to [Noise Reduction] and press [HOME] key to confirm to enter the noise reduction page as shown in below figure.

NOISE REDUCTION		
▶	2D NR	Auto
	3D NR	Auto
▲▼ Select Item		
◀▶ Change Value		
[Menu] Exit		

2D NR (2D Noise Reduction): Auto, Close 1 ~ 5.

3D NR (3D Noise Reduction): Auto, Close, 1 ~ 8.

5.7 AUDIO

When in main menu page, move the cursor to [AUDIO] and press [HOME] key to confirm to

enter the audio page as shown in below figure.

AUDIO		
▶	AUDIO SOURCE	LINE
▲▼ Select Item		
◀▶ Change Value		
[Menu] Exit		

Audio Source: LINE, Off.

5.8 SETUP

When in main menu page, move the cursor to [Setup] and press [HOME] key to confirm to enter the setup page as shown in below figure.

SETUP		
▶	Language	English
	USB Mode	BULK
	OSD Flip	Off
	UVC Standby Mode	On
	Wakeup Pos	Preset 0
▲▼ Select Item		
◀▶ Change Value		
[Menu] Exit		

Language: English, Chinese.

USB Mode: BULK, ISOC.

OSD Flip: On, Off.

UVC Standby Mode: On, Off.

Wakeup Pos: Preset 0, Preset UVC

5.9 COMMUNICATION SETUP

When in main menu page, move the cursor to [Communication Setup] and press [HOME] key to confirm to enter the communication setup page as shown in below figure.

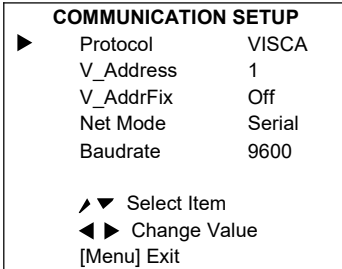

Protocol: VISCA, PELCO-D, PELCO-P.

V_Address: 1 ~ 7 (Effective only in VISCA protocol).

V_AddrFix: On, Off (When set to On, the 88 30 01 FF command does not work. Effective only in VISCA protocol).

P_D_Addr: 0 ~ 254 (Effective only in PELCO-D protocol).

P_P_Addr: 0 ~ 31 (Effective only in PELCO-P protocol).

Net Mode: Serial, Paral (Effective only in VISCA protocol).

Baudrate: 2400, 4800, 9600, 19200, 38400.

5.10 INFORMATION

When in main menu page, move the cursor to [Information] and press [HOME] key to confirm to enter the information page to check the product information as shown in below figure.

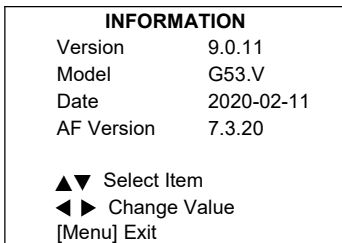

Note

The above information is for reference only, please refer to the real product for the actual specification.

5.11 RESTORE DEFAULT

When in main menu page, move the cursor to [Restore Default] and press [HOME] key to confirm to enter the restore default page as shown in below figure.

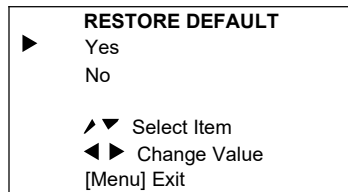

Restore: Yes, No.



Notice

When selected “Yes” and confirm with [HOME] key, all parameters will restore to default, include the IR Remote address and VISCA address.



GUI menu and parameters are subject to change without notice.

6 Maintenance and Troubleshooting

Camera Maintains

- If camera will not be used for a long time, disconnect the AC power adapter from the AC outlet.
- Use soft cloth or tissue to clean the camera cover.
- Please use the soft dry cloth to clean the lens. If the camera is very dirty, clean it with diluted neuter detergent. Do not use any type of solvents, which may damage the surface.

Unqualified Application

- Do not shooting extreme bright object, such as sunlight, light sources, etc.
- Do not operating under unstable lighting conditions, otherwise the image will be flickering.
- Do not operating close to powerful electromagnetic radiation, such as TV or radio transmitters, etc.

Troubleshooting Image

There have no image shows on the monitor

- 1) Check that the camera power supply is connected, the voltage is normal, and the power indicator light is always on.
 - 2) Unplug and restart the camera to check that the camera is available for self-testing.
 - 3) Check that the cable connection of the video platform or TV is correct.
 - Image jitters after the camera is properly connected
- 1) Check that the camera installation position is stable.
 - 2) Check that any vibrating machinery or object near the camera.

Control

- Remote control does not work
- 1) Check and replace with new batteries.
 - 2) Check that the camera is in normal working mode.
 - 3) Check the address key of remote control can match the camera.
- Serial port cannot control
- 1) Check the protocol, address and bit rate of the camera are consistent.
 - 2) Check the control cable is properly connected.